

Real size

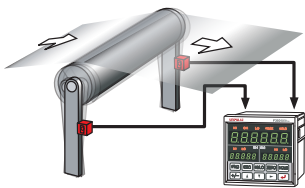

**2ch allows ease in use!!**  
Load and pressure are controlled at high speed and high accuracy.



Tension measurement

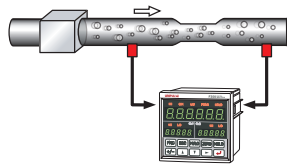

Pressure control

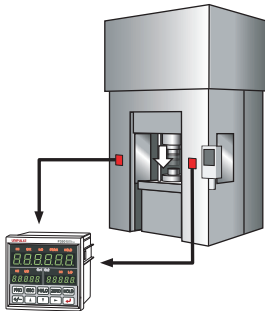

Press load measurement

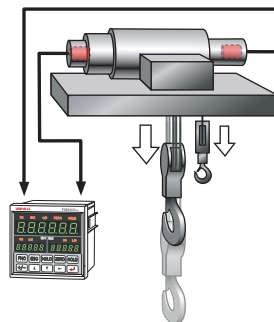

Crane load measurement

The F350 is a digital indicator that is capable of two-channel inputs of strain gauge type sensors. Equipped with calculation functions, such as  $ch1+ch2$  and  $ch1-ch2$ , the F350 is best suited for total, difference, balance, and other load measurements.

### 2ch inputs

Calculation and judgment outputs can be made with respect to 2ch input values of strain gauge type sensors. Calculated value is displayed on the main display, and ch1 and ch2 input values are displayed on the sub display.

### Calculation functions

- $ch1+ch2$  ..... The ch1 value and ch2 value are added.
- $ch1-ch2$  ..... The ch2 value is subtracted from the ch1 value.
- $|ch1-ch2|$  ..... The difference value between the ch1 value and ch2 value.
- High select..... The ch1 value or ch2 value, whichever is larger, is selected.
- Low select..... The ch1 value or ch2 value, whichever is smaller, is selected.

### 9 points of judgment outputs are equipped.

Calculated value: HI, OK, LO; ch1 value: HI, LO, Alarm output; ch2 value: HI, LO, Alarm output

### Sampling speed as high as 3000 times/sec on each channel

Including the high-speed CPU that allows processing from sensor inputs to outputs at 3000 times/sec, the F350 captures necessary points reliably. (The speed can be switched to 300 times/sec.)

### Equivalent input calibration function

Calibration is performed by simply key-inputting the rated output value and rated capacity value of the sensor.

If an actual load cannot be applied, or when the load cell is replaced, calibration can be easily performed by key operation.

### Digital zero & Digital offset

The indicated value can be zeroed by key operation. The F350 is also equipped with the function of subtracting a set value from the indicated value.

This function is convenient in the case where a no-load condition cannot be set up or for offsetting.

### Analog voltage output

Voltage in proportion to the input signal, which is useful for recording with a recorder, etc., can be output on each channel.

## HI and LO limit comparison functions with hysteresis

Timing at which HI and LO limit comparisons are made can be provided with a margin. This function is effective to prevent chattering, etc.

### HI and LO limit output time chart (calculated value)

Only HI and LO outputs are made on ch1 and ch2.

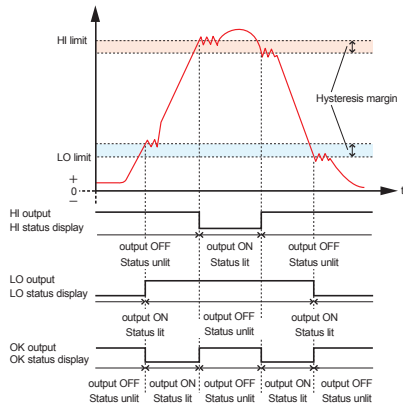

## Hold functions

The F350 is equipped with hold functions of calculated values (sample, peak, bottom, and average). Section setting can also be made by external signal.

### Example 1) Sample hold

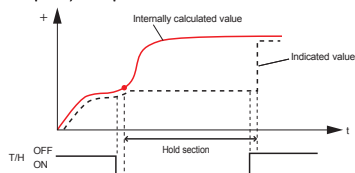

### Example 2) All section peak hold

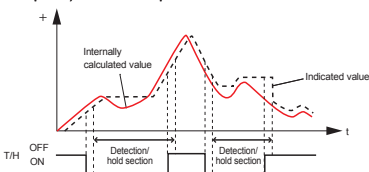

### Example 3) Externally specified section average hold

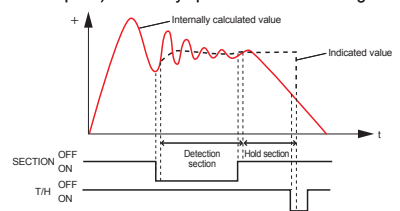

## SPECIFICATIONS

|   |   |
|---|---|
| <b>Analog</b><br>Number of sensor inputs<br>Excitation voltage<br>The following are common to each input.<br>Signal input range<br>Equiv. input cal. range<br>Zero-Gain adjustment range<br>Accuracy<br><br>Analog filter<br>A/D converter<br>Analog monitor output   | 2 inputs (strain gauge input)<br>DC10V, 2.5V ±5% (depending on settings.) Output current: 60mA or less (2 channels total)<br>-3.0 ~ +3.0mV/V<br>-3.0 ~ -0.5mV/V, +0.5 ~ +3.0mV/V<br>Automatic adjustment via digital processing<br>Non-linearity..... Within 0.02%/FS±1digit (at a 3.0mV/V input)<br>Zero drift..... Within 0.5µV/°C RT1<br>Gain drift..... Within 0.01%/°C<br>Selectable 3, 30, 300, 1k Hz<br>Selectable from 3000 times/sec and 300 times/sec<br>1/10000 to 1.0 mV/V<br>output level: strain gauge input is approx. 2V per 1mV/V Load resistance: 2kΩ or more   |
| <b>Display</b><br>Display unit<br>Indicated value<br>Display frequency<br>Status display  | Character height 14.6mm Numerical display by 7-segment green LED (6-digit)<br>Character height 8mm Numerical display by 7-segment green LED (5-digit)<br>5-digit ±8.8.8.8.8 -99999 ~ +99999 Signs: Minus sign on most significant digit<br>5-digit ±8.8.8.8.8 -19999 ~ +19999 Signs: Minus sign on most significant digit<br>Selectable from 3, 6, 13, and 25 times/sec.<br>HI / OK / LO / PEAK / HOLD / HI (ch1) / LO (ch1) / HI (ch2) / LO (ch2)  |
| <b>Setting</b><br>Setting item  | Hold section setting (All section-External signal-External signal + Time)<br>Work setting (comparison): Calculated value HI limit / Calculated value LO limit / ch1,2 HI limit / ch1,2 LO limit<br>Work setting (comparison/hold): Comparison function select / Near zero / Hysteresis / Calculation hold function select / Detection time / Average sample number<br>System setting (calculation/common operation) : MD / SI/F function select / Display frequency<br>System setting (ch operation): Digital filter / Analog filter / ZT / D/Z synchronous mode / A/D conversion speed select<br>Calibration setting (ch calibration): Calibration function select / Zero calibration / Equivalent input calibration / Actual load calibration / Digital offset / Alarm HI limit / Alarm LO limit<br>System setting (BCO option): Output data select / Output rate / BCD/binary select<br>System setting (232 option): Communication mode / Communication condition / Delimiter<br>System setting (DAV / DAI option) : Output data select / Zero scale value / Full scale value<br>Protect/initialize: Setting protect / Key protect / Initialize / Password   |
| <b>Hold</b><br>Sample, Peak, Bottom, Average  | Hold section setting (All section-External signal-External signal + Time)   |
| <b>External signal</b><br>External output signal (11)<br>External input signal (4)  | HI/LO limit comparison (HI (calculation) ·OK (calculation) ·LO (calculation) ·HI (ch1) ·LO (ch1) ·HI (ch2) ·LO (ch2) ) / alarm (ch1) / alarm (ch2) / hold complete / RUN<br>Open collector output circuit (sink type) V <sub>ceo</sub> =30V (max) I <sub>c</sub> =30mA (max)<br>hold section control / hold release / digital zero 1 / digital zero 2<br>Dry contact input circuit (minus common type) I <sub>c</sub> =10mA or less   |
| <b>Interface</b><br>SIF<br>BCO<br>DAV<br>DAI<br>232   | 2-wire serial interface<br>Connect to a UNIPULSE-manufactured printer, external display, etc.<br>Transmitting method: Asynchronous Baud rate: 600bps<br>Output data: Allocations to the GROSS area and NET area are selected by the setting of "calculated value & ch1 value", "calculated value & ch2 value", or "ch1 value & ch2 value."<br>BCD parallel data output interface (Option)<br>Open collector output circuit (sink type) Data format: BCD or binary selectable<br>Output rate: 10/30/50/100/300/500/1000 times/sec.<br>Rated voltage: 30V Driving capacity: 30mA or less<br>Output data: Selected by the setting of "calculated value", "ch1 value", or "ch2 value", or externally.<br>D/A converter voltage output (Option)<br>Output range: ±10V Load resistance: 2kΩ or more<br>Zero/span adjustment range: ±10% F.S.<br>Output data: Selected by the setting of "calculated value", "ch1 value", or "ch2 value."<br>D/A converter current output (Option)<br>Output range: 4 ~ 20mA Load resistance: 350Ω or less<br>Zero/span adjustment range: ±10% F.S.<br>Output data: Selected by the setting of "calculated value", "ch1 value", or "ch2 value."<br>RS-232C communication interface (Option)<br>Transmitting method: Asynchronous Baud rate: 9600bps ~ 57600bps<br>Flow control: RTS/CTS controllable |
| <b>General Specification</b><br>Power supply voltage<br>Power consumption<br>Operating conditions<br>Dimension<br>Weight  | AC100 ~ 240V +10%~15% (free power source) 50/60Hz<br>10W<br>Temperature..... Operation: -10 ~ +40°C Storage: -40 ~ +80°C<br>Humidity..... 85%RH or less (non-condensing)<br>96 (W) ×96 (H) ×138 (D) mm (Protrusions excluded)<br>Approx. 1.0kg  |
| <b>Attachment</b><br>AC supply cord (Nominal rating 125V) 3m ..... 1<br>AC supply cord converter plug for AC supply cord ..... 1<br>FCN series I/O connector (with cover) ..... 1<br>Ferrite core ..... 2   | Operation manual..... 1<br>BCD output connector (when BCD output option is selected) ..... 1<br>Mini driver (D/A converter option is selected) ..... 1  |
| <b>Accessories</b><br>CA372-I/O: End treatment 24-leads cable with FCN connector at one end 3m<br>CAAC3P-B3: AC supply cord (Nominal rating 125V) 3m<br>CAAC3P-CEE7I7-B2: AC supply cord (voltage resistance 250V) 2m<br>CN3P-2P: AC supply cord converter plug for AC supply cord<br>CN34: D-Sub9p connector for RS-232C | CN50: FCN series I/O connector (with cover)<br>CN51: BCD output connector<br>CN55: FCN series I/O connector (with diagonal cover)<br>CN81: Analog I/O connector terminal  |
| <b>CE marking certification</b><br>·EMC directive EN61326<br>·Safety standard EN61010-1   |   |

## DIMENSIONS

Unit: mm

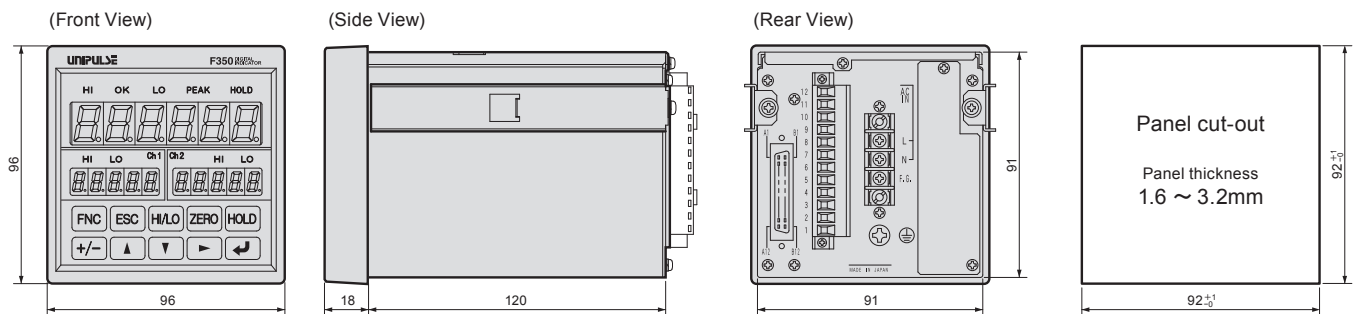

\* Please note that specifications or designs shown in this catalog may be changed without prior notice due to our continuous product improvement activities.

<http://www.unipulse.com>

## UNIPULSE CORP.

International Sales Department  
 Nittetsu Kobiki Bldg 7-16-3 Ginza,  
 Chuo-ku, Tokyo 104-0061  
 Tel: +81-3-5148-3000  
 Fax: +81-3-5148-3001

Headquarter:  
 Technical Center:  
 Nagoya Sales Office:  
 Osaka Sales Office:  
 Hiroshima Sales Office:  
 Fukuoka Sales Office:

Nittetsu Kobiki Bldg 7-16-3 Ginza, Chuo-ku, Tokyo 104-0061  
 1-3 Sengendainishi, Koshigaya, Saitama 343-0041  
 CK16 Fushimi Bldg 1-24-25 Sakae, Naka-ku, Nagoya 460-0008  
 Sumitomo Seimei Shin Osaka Kita Bldg 4-1-14 Miyahara, Yodogawa-ku, Osaka 532-0003  
 Funairi Reiku Bldg 9-20 Funairihonmachi, Hiroshima 730-0843  
 Tada Bldg 1-16 Tsunaba-cho, Hakata-ku, Fukuoka 812-0024